

In Clyde's Default Behavior eye presses cycle Clyde through 4 internal states: color light on, color light and task light on, task light on and off. Clyde has plug-and-play modules that control additional behavior states. These additional states can only be accessed through default states. This is to say that all transitions between behavior states must pass through the Default Behavior

CLYDE DEFAULT BEHAVIOR STATE DIAGRAM

Clyde Behavior without Personality Modules

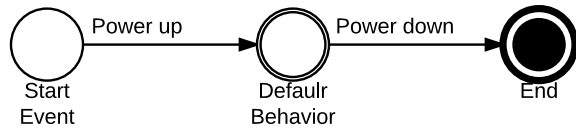

Clyde Behavior with Personality Modules

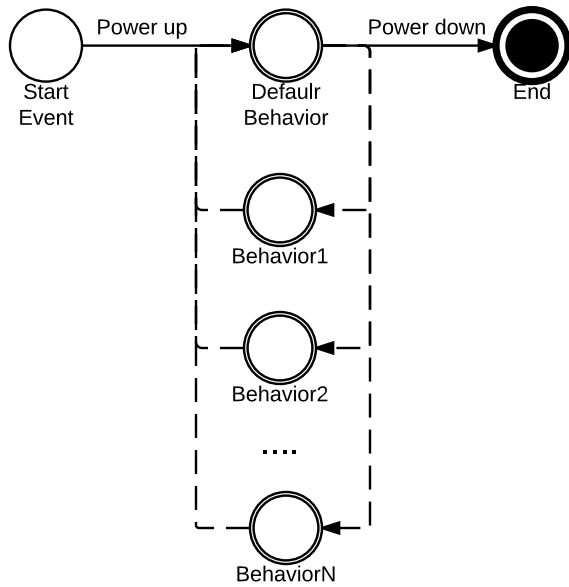

Clyde Default Behavior Internal States

